

# VEROTEC

Electronics Packaging

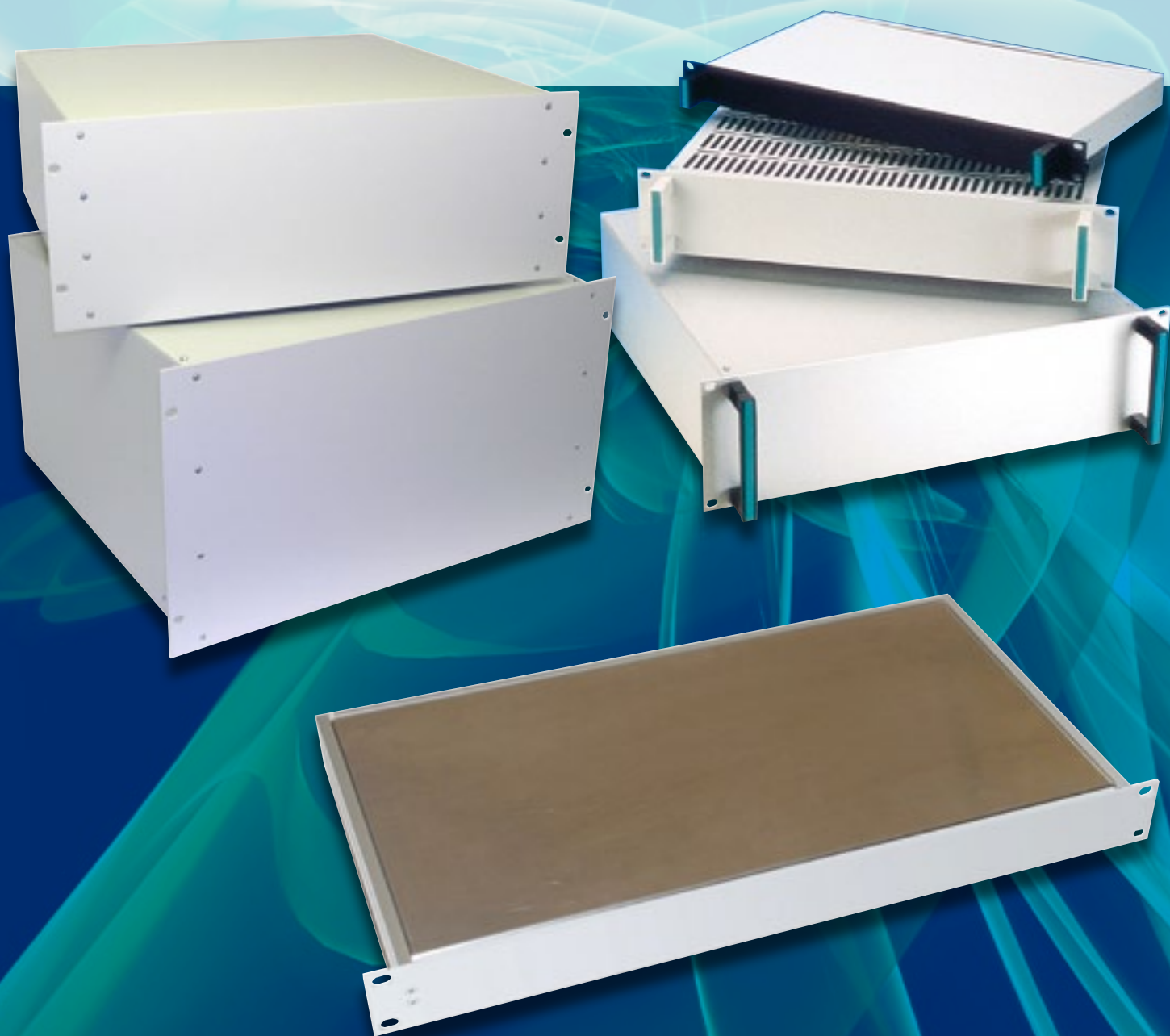
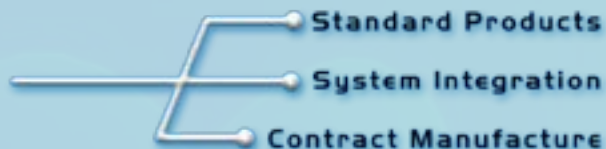

**19" Rack Cases**

# 19" Rack Cases

## APPLICATIONS

19" rack cases are designed to offer a simple solution to many 19" mounting applications. The design allows numerous combinations to be assembled according to the application and hence offers total flexibility for the design engineer, using common piece parts. It also allows the case to be presented in a number of attractive finishes for individual product tailoring of 19" mounting applications.

## FEATURES

- Conforms to IEC 297-1, DIN 41494
- Simple design for total access
- Three depth variations
- Six height variations
- Numerous configurations for total flexibility

Standard heights are 1U, 2U and 3U. Heights of 4U, 5U and 6U are subject to MOQ

## CONTENTS OF KIT

Item/Description	Material/Finish
Top and base	0.9mm steel, Painted RAL 7035 Grey
Front panels	3mm anodized aluminium (clear) or 2mm steel painted black
Rear panels	0.9mm steel, Painted RAL 7035 Grey
Handles	ABS RAL 7035 or black and clear/black anodised aluminium extrusion.

## CONFIGURATION & ORDERING

Please see the following page for full configuration details of options and order code table.

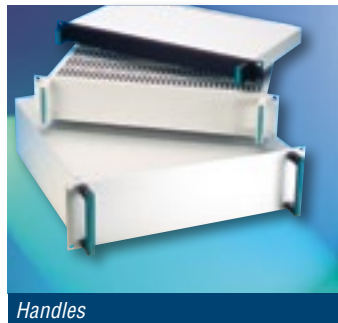

Handles



The top

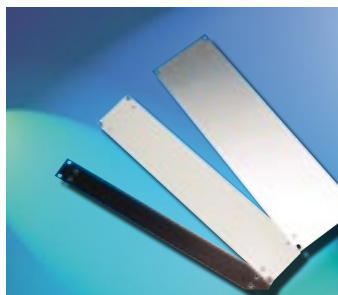

Front panels



The base



Rear panels



19" RACK CASES

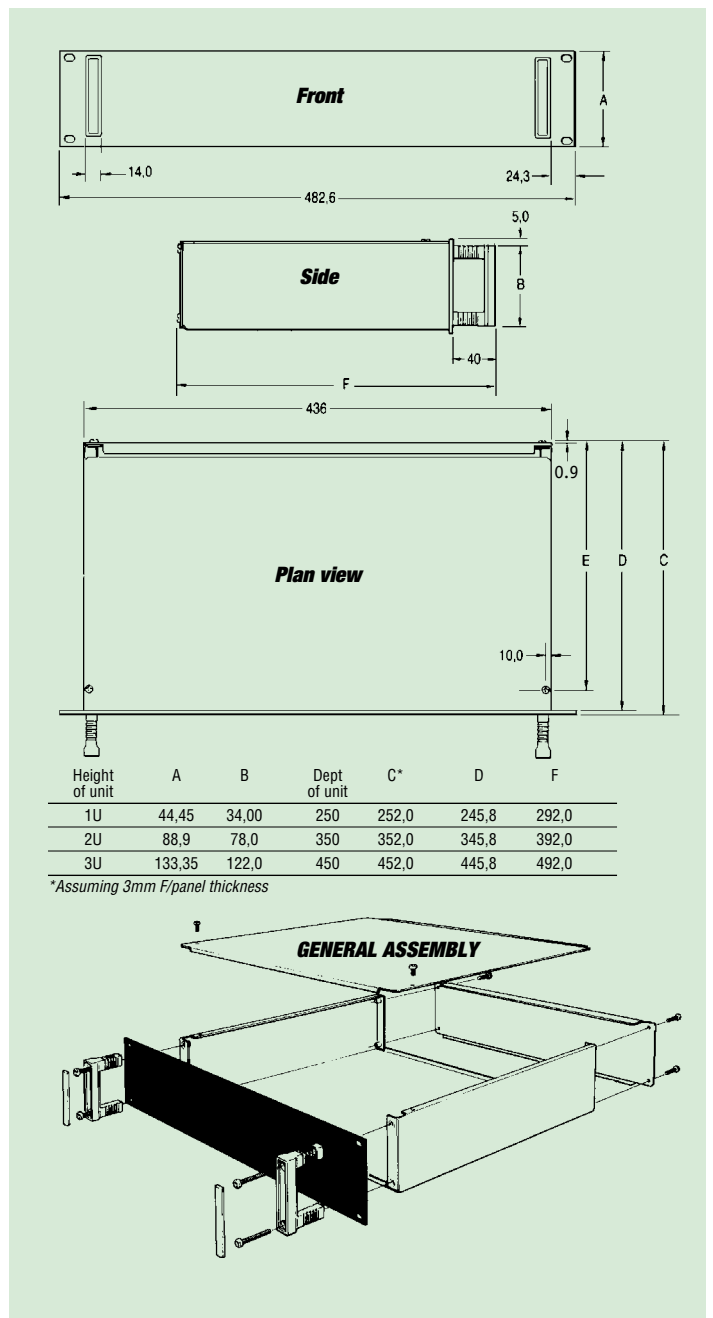

# 19" Rack Cases

## HOW TO CONFIGURE THE RACK CASE

Since it is generally accepted that the case will consist of a top, base, front and rear, the following example illustrates how to select the configuration which best suits you.

### THE TOP

This is available in 3 depths of 250mm, 350mm and 450mm in a ventilated and unventilated version and is simply attached to the case by means of two fasteners at the front.

### HANDLES

These are available in 1U, 2U and 3U versions and can be either black or grey. They attach to the case using 4 fixing screws through the front panel fixing centres.

### THE BASE

This is available in 3 depths of 250mm, 350mm and 450mm and three heights of 1U, 2U and 3U. It is also available in ventilated and unventilated versions.

### FRONT PANELS

These are available in clear anodised aluminium or black painted and are attached to the base by means of 4 screw fixings. There are 3 height variations of 1U, 2U and 3U and all will accept front panel handles.

**Delivery:** Please note that all units will be supplied assembled.

### REAR PANELS

These are available in RAL 7035 painted steel and are attached to the base by 4 screw fixings. There are 3 height variations of 1U, 2U and 3U and all are removable.

## ORDERING INFORMATION

Top covers	250mm	350mm	450mm
Ventilated	503-232963	503-232965	503-232967
Unventilated	503-232964	503-232966	503-232968

Base 1U	250mm	350mm	450mm
Ventilated	503-232945	503-232951	503-232957
Unventilated	503-232946	503-232952	503-232958

Base 2U	250mm	350mm	450mm
Ventilated	503-232947	503-232953	503-232959
Unventilated	503-232948	503-232954	503-232960

Base 3U	250mm	350mm	450mm
Ventilated	503-232949	503-232955	503-232961
Unventilated	503-232950	503-232956	503-232962

Front panels	1U	2U	3U
Black painted	503-232970	503-232973	503-232976
Clear anodise	503-232971	503-232974	503-232977

Rear panels	1U	2U	3U
RAL 7035 painted steel	503-232984	503-232985	503-232986

Handles	1U	2U	3U
Black	503-232978	503-232980	503-232982
Grey	503-232979	503-232981	503-232983

*Note: Care should be taken with 1U and 2U 450mm deep versions not to excessively weight load the unit without the use of additional chassis supports.*



The top

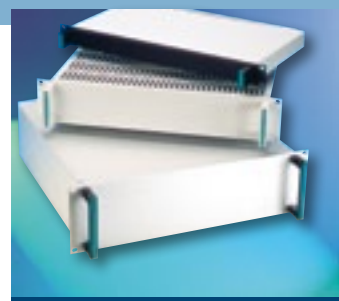

Handles



The base

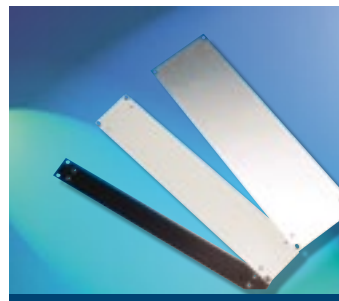

Front panels



Rear panels

## CONFIGURED PART NUMBERS:

So that specific permutations can be provided, it is now possible to configure exact requirements using the chart below. Each digit of the order code represents an available option for example, part number 519-110113 represents a 1U rack case, 250mm deep with a plain top cover and base, clear anodised front panel and grey handles. Configured units will be supplied assembled.

## RACK CASE CODE GENERATOR

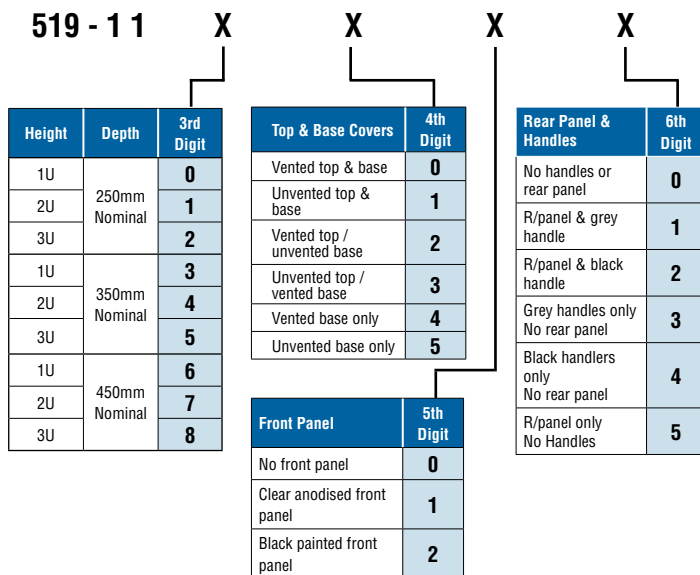

# 19" Rack Cases

## 4U, 5U AND 6U RACK CASES

In addition to the standard 1U, 2U and 3U versions, we also offer 4U, 5U and 6U rack cases, suiting applications where more space is required. The basic construction is very similar to the standard cases, the only difference being the front panel is secured to the base with four screws either side as opposed to two. 4U, 5U and 6U rack cases can be supplied either assembled or in kit form

## ORDERING INFORMATION

There is a minimum order quantity of ten pieces for these products with ordercodes being assigned on a per order / enquiry basis. For a quotation or technical details, please contact our sales office with your configuration requirements from the table below:

Description	Options
Height	4U / 5U / 6U
Depth	250mm / 350mm / 450mm
Front Panel Finish	Silver Anodise / Black Paint
Rear Panel	Fitted / Not Fitted
Handles	Grey / Black, Fitted / Not Fitted
Supply	Assembled / Kit Form

## RACK CASE ACCESSORIES

### Chassis Supports

These steel chassis supports can be varied along the depth of the rack and provide an ideal method of mounting heavy rack cases. They position the rack cases accurately in line with Unit heights and align the front panel mounting holes with the rack fixings. Chassis supports are sold in pairs and have a load rating of 50KG.

*Note: These chassis supports are designed primarily for IMRAK and VERAK cabinets. Please check drawing below for compatibility with other 19" cabinets*

### Contents of kit

Description	Qty	Material	finishes
Chassis Support	2	1.5 mm steel	Light grey RAL 7035
fixing			
Load rating and safety specification			
50 kg			

### Ordering Information

Length (min cabinet depth)	Order code
470 mm (600 mm)	960-4001285
670 mm (800 mm)	960-4001704



19" RACK CASES

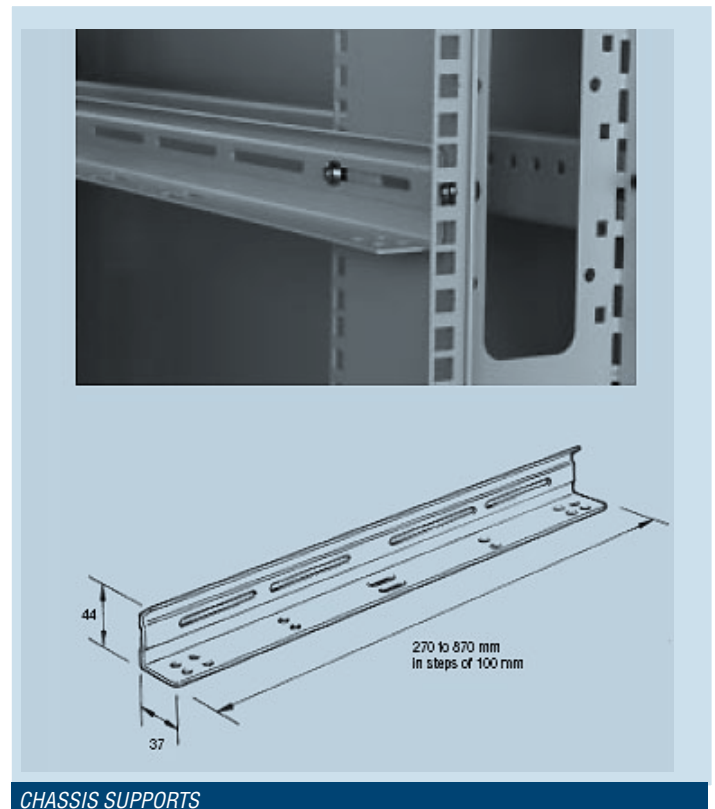

CHASSIS SUPPORTS

## EMC RACK CASE

The EMC Rack case is designed for applications that demand a high level of EMC screening and cosmetic appeal without compromising on strength and usability. The EMC Rack case is constructed with light-weight, extruded aluminium front, rear and side panels with interlocking aluminium top and bottom covers. This "sealed" design provides excellent EMC performance whilst making it easy to gain access to the electronics within.

### Features:

- Conforms to IEC 297-1, DIN 41494
- Lightweight yet robust construction
- Good Aesthetic Design
- High EMC Performance
- Easy Access
- Customizing Options
- Three Height Options
- Two Depth Options
- Supplied Assembled

### Applications:

- Broadcast
- Audio
- Datacoms
- Networking
- Instrumentation

### Material and Finish

Description	Material / finish
Front / Rear Panel	3mm Aluminium (Extruded), Anodized
Top / Bottom covers	1mm Aluminium
Sides	Extruded Aluminium, plastic trims

### Ordering Information

Description	Ordercode
1U 250mm EMC Rack case	<b>503-4000963</b>
1U 350mm EMC Rack case	<b>503-4000964</b>
2U 250mm EMC Rack case	<b>503-4001700</b>
2U 350mm EMC Rack case	<b>503-4001701</b>
3U 250mm EMC Rack case	<b>503-4001702</b>
3U 350mm EMC Rack case	<b>503-4001703</b>

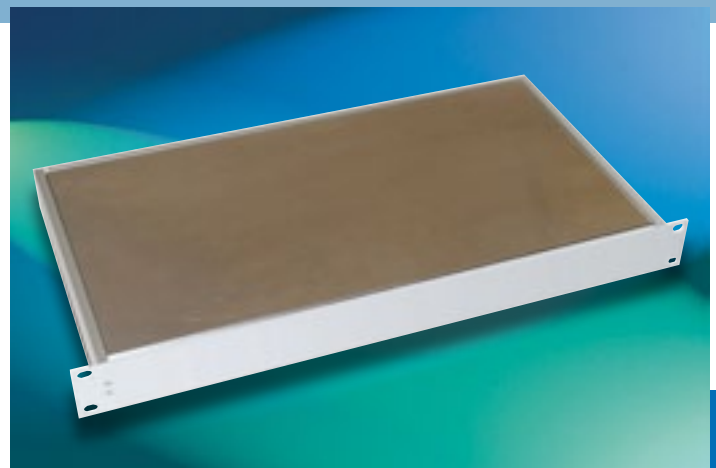

EMC RACK CASES

Light-weight, extruded front, rear and side panels mean a strong construction and excellent EMC shielding is achieved

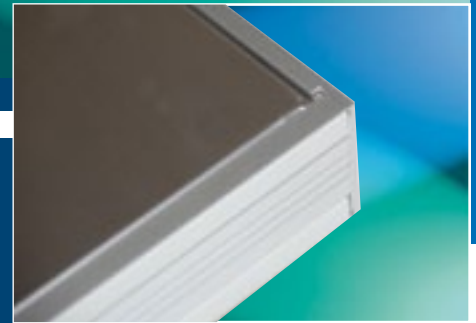

Removable plastic side trims are available in different colours to enhance cosmetics and match customer's colour schemes



Fast and simple removal of top cover means easy assembly and quick access for servicing / maintenance.



Front and rear panels can be easily removed with four screws allowing easy modification. Customer specific machining, silk screening, painting etc. can be provided by Verotec – please ask for details

