

SNAP-AIPM Modules

Features

- Convenient pluggable wiring
- Single-phase or three-phase power monitoring
- Monitors AC RMS voltage and AC RMS current; calculates true power and volt-amps
- 10% over range
- 25,000 counts of resolution over input ranges
- Out-of-range indication
- Factory calibrated; no user adjustment necessary



SNAP-AIPM Module

Description

The SNAP-AIPM analog input modules provide an efficient way to monitor AC voltage and current using a SNAP PAC rack-mounted controller or SNAP PAC brain. Two models are available:

- The **SNAP-AIPM** monitors single-phase AC power.
- The **SNAP-AIPM-3** monitors three-phase AC power.

Both modules mount on a SNAP PAC rack right alongside digital, analog, and serial SNAP I/O™ modules.

SNAP-AIPM modules help you measure and control power usage, so you can reduce costs, maintain power quality, and track energy use. If they are part of a SNAP PAC System running a PAC Control™ strategy, strategy logic can automatically perform additional calculations and respond to any problems the module reports.

SNAP racks use a retention rail locking system that holds modules securely to the rack. Normally, a hold-down screw is not required. However, for applications that require additional module security, each module has provisions for two 4-40 by 1/2-inch standard machine screws to hold each module in position on the SNAP rack.

SNAP-AIPM

The SNAP-AIPM individually and simultaneously measures single-phase AC volts RMS and amps RMS and calculates true power and volt-amps. Power factor can then be calculated from true power and volt-amp values. Because true power is a signed value, either leading or lagging power factor can be calculated.

The SNAP-AIPM module is designed for 85–250 volts and 0–10 amps, but it can also monitor AC line currents greater than 10 amps using a standard 5-Amp current transformer (CT) of suitable ratio. For line voltage larger than 250 VAC, use a step-down potential

transformer. If hazardous voltage or current is to be monitored, an interposing potential transformer and a CT **must** be used for safety.

The SNAP-AIPM module offers four channels (points) of data, two from wired inputs and two calculated by the module:

Pt	Data	Data Source
0	0–250 AC VRMS	Measured from VRMS input
1	0–10 AC ARMS	Measured from ARMS input
2	True Power	Calculated from synchronous measurement of volts and amps
3	Volt-Amps	Calculated (VRMS x ARMS)

To calculate power factor, simply use the data in points 2 and 3 in the formula: Power Factor = (True Power Magnitude) / (volt-amps).

SNAP-AIPM-3

The SNAP-AIPM-3 includes 14 channels of data, some from wired inputs and some calculated by the module. All channels are shown in the table on the following page. For each of the three phases, the module includes the same four channels as in the SNAP-AIPM (see above); in addition, it includes two summation values. Calculations occur within the module and are sent to the SNAP PAC brain or rack-mounted controller.

For safety, the SNAP-AIPM-3 requires two transformers per phase, one for voltage and one for current.

Part Number

Part	Description
SNAP-AIPM	Single-phase Power Monitoring Module, 85–250 V RMS and 0–10 A RMS Inputs
SNAP-AIPM-3	Three-phase Power Monitoring Module, 85–250 V RMS and 0–10 A RMS Inputs Each Phase

SNAP-AIPM Modules

Data Channels for SNAP-AIPM-3

Pt	Data	Data Source
0	0–250 AC VRMS	Phase A: Measured from VRMS input
1	0–10 AC ARMS	Phase A: Measured from ARMS input
2	True Power	Phase A: Calculated from synchronous measurement of volts and amps
3	Volt-Amps	Phase A: Calculated (VRMS x ARMS)
4	0–250 AC VRMS	Phase B: Measured from VRMS input
5	0–10 AC ARMS	Phase B: Measured from ARMS input
6	True Power	Phase B: Calculated from synchronous measurement of volts and amps
7	Volt-Amps	Phase B: Calculated (VRMS x ARMS)
8	0–250 AC VRMS	Phase C: Measured from VRMS input
9	0–10 AC ARMS	Phase C: Measured from ARMS input
10	True Power	Phase C: Calculated from synchronous measurement of volts and amps
11	Volt-Amps	Phase C: Calculated (VRMS x ARMS)
12	1-second E	True Power sum ABC (signed)
13	1-second abs E	True Power sum of absolute value of each A, B, and C (always positive)

Specifications

	SNAP-AIPM	SNAP-AIPM-3
Voltage Inputs (each voltage channel)		
Recommended Input Range	85 to 250 VAC RMS	85 to 250 VAC RMS
Scaled Input Range	0 to 250 VAC RMS	0 to 250 VAC RMS
Input Over Range	To 275 volts	To 275 volts
Resolution	10 mV	10 mV
Accuracy (47 to 63 Hz)	(When used within recommended range) ± 0.2 V and ± 0.2% reading (at full scale = ± 0.7 V or 0.28%) (–0.2 dB at 660 Hz; –3 dB at 1.89 kHz) nominal	(When used within recommended range) ± 0.2 V and ± 0.2% reading (at full scale = ± 0.7 V or 0.28%) (–0.2 dB at 660 Hz; –3 dB at 1.89 kHz) nominal
RMS Integration Time/ Data Freshness	1000 ms (synchronous with current measurement)	1000 ms (synchronous with current measurement)
Input Filtering	Time constant = 70 µs (analog front end)	Time constant = 70 µs (analog front end)
Input Resistance – Single Ended	1 Megohm NOTE: Because both channels share the same reference terminal, polarity must be observed when connecting the current channel.	1 Megohm NOTE: Because both channels share the same reference terminal, polarity must be observed when connecting the current channel.
Maximum Input	300 V non-operating	300 V non-operating

Isolation

All SNAP analog input modules, including the SNAP-AIPM and SNAP-AIPM-3, are transformer isolated as well as optically isolated from all other modules and from the SNAP PAC brain or rack-mounted controller.

Optical isolation provides 4,000 volts of transient (4,000 V for 1 ms) protection for sensitive control electronics from industrial field signals. Transformer isolation prevents ground loop currents from flowing between field devices and causing noise that produces erroneous readings. Ground loop currents are caused when two grounded field devices share a connection, and the ground potential at each device is different.

However, note that the SNAP-AIPM modules' input points are *not* isolated from each other. Because they share the same reference terminal, polarity must be observed.

Note for legacy hardware: The SNAP-AIPM module can also be used with SNAP Ultimate, SNAP Ethernet, and SNAP Simple brains and on a SNAP M-series or B-series mounting rack.

The SNAP-AIPM-3 cannot be used with legacy hardware. It requires a SNAP PAC brain or rack-mounted controller.

SNAP-AIPM Modules

	SNAP-AIPM	SNAP-AIPM-3
Current Inputs (each current channel)		
Input Range	0 to 10 AC amps RMS	0 to 10 AC amps RMS
Input Over Range	To 11 amps (Reading is not reliable over 11 A.)	To 11 amps (Reading is not reliable over 11 A.)
Input Overload	15 A continuous, non-operating	15 A continuous, non-operating
Resolution	400 μ A	400 μ A
Accuracy (47 to 63 Hz)	± 8 mA and $\pm 0.2\%$ reading (at full scale = ± 28 mA or 0.28%) (-0.2 dB at 660 Hz; -3 dB at 1.89 kHz) nominal	± 8 mA and $\pm 0.2\%$ reading (at full scale = ± 28 mA or 0.28%) (-0.2 dB at 660 Hz; -3 dB at 1.89 kHz) nominal
RMS Integration Time/ Data Freshness	1000 ms (synchronous with voltage measurement)	1000 ms (synchronous with voltage measurement)
Input Filtering	Time constant = 105 μ s (analog front end)	Time constant = 105 μ s (analog front end)
Input Resistance – Single Ended	0.005 Ohm NOTE: Because both channels share the same reference terminal, polarity must be observed when connecting the voltage channel.	0.005 Ohm NOTE: Because both channels share the same reference terminal, polarity must be observed when connecting the voltage channel.
Maximum Input	15 A continuous, non-operating	15 A continuous, non-operating
All Inputs (each channel)		
True Power and Volt-Amps Range	True power: 2500.0 Watts. Volt-amps: 2500.0 volt-amps (inputs = 250 volts and 10 amps)	True power: 2500.0 Watts. Volt-amps: 2500.0 volt-amps (inputs = 250 volts and 10 amps)
Over Range	2750 Watts true power or 27,500 counts volt-amps	2750 Watts true power or 27,500 counts volt-amps
Accuracy:		
True Power	$\pm 0.6\%$ reading (at full scale = ± 15 Watts)	$\pm 0.6\%$ reading (at full scale = ± 15 Watts)
Volt-Amps	$\pm 0.6\%$ reading (at full scale = ± 15 VA)	$\pm 0.6\%$ reading (at full scale = ± 15 VA)
Resolution	100 Megohms	100 Megohms
AC Common Mode Rejection	>-120 dB at 60 Hz	>-120 dB at 60 Hz
Maximum Operating Common Mode Voltage	250 VAC	250 VAC
Power Requirements	5.0 VDC ± 0.15 VDC at 100 mA	5.0 VDC ± 0.15 VDC at 100 mA
Ambient Temperature:		
Operating	0 to 70 $^{\circ}$ C	0 to 70 $^{\circ}$ C
Storage	-25 to 85 $^{\circ}$ C	-25 to 85 $^{\circ}$ C

SNAP-AIPM Modules

Wiring Diagrams—SNAP-AIPM

Single Phase Standard Wiring Diagram

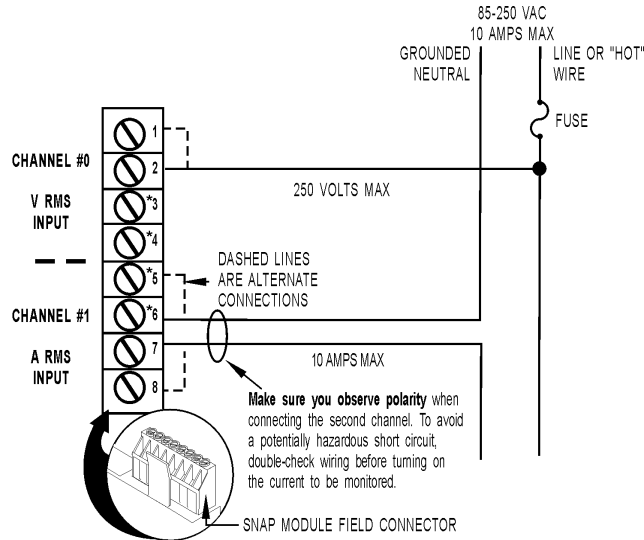

* Pins 3,4, 5, and 6 are internally connected.

CAUTION: Be very careful when connecting input channels. Do not connect line voltage to the current input channel; such a connection will result in **severe damage** to the module. This damage is **not covered by warranty**.

CAUTION: Use caution when selecting wire gauges for your application. Use conservative wire gauges with proper voltage ratings.

CAUTION: Terminals 3, 4, 5, and 6 share a common connection inside the module.

CAUTION: The SNAP-AIPM module does not contain a fuse. Protect the system by adding a fuse. See below for a suggested vendor.

Suggested vendors

Protection fuses: <http://www.littelfuse.com>

Voltage and current transformers: <http://www.crmagnetics.com>

Measuring AC Line Current Greater Than 10 Amps with a Current Transformer

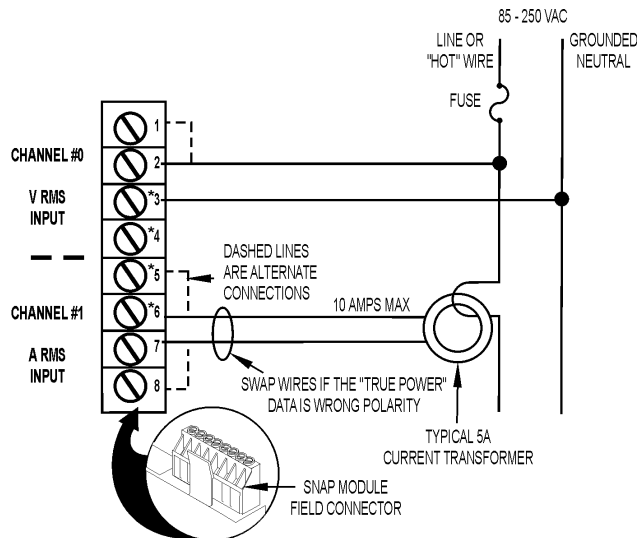

* Pins 3,4, 5, and 6 are internally connected.

Measuring AC Voltage with a Voltage Transformer and a Current Transformer

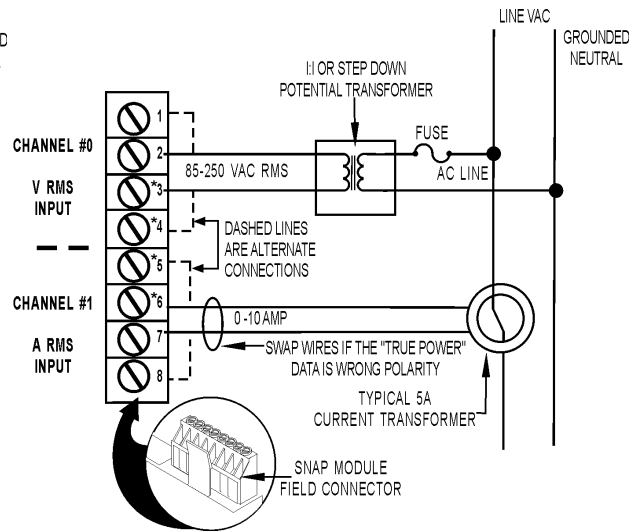

* Pins 3,4, 5, and 6 are internally connected.

SNAP-AIPM Modules

Wiring Diagrams—SNAP-AIPM (continued)

Three-Phase Wiring to Three SNAP-AIPM Modules

See cautions on [page 4](#). If you have a SNAP-AIPM-3 module, see [page 7](#).

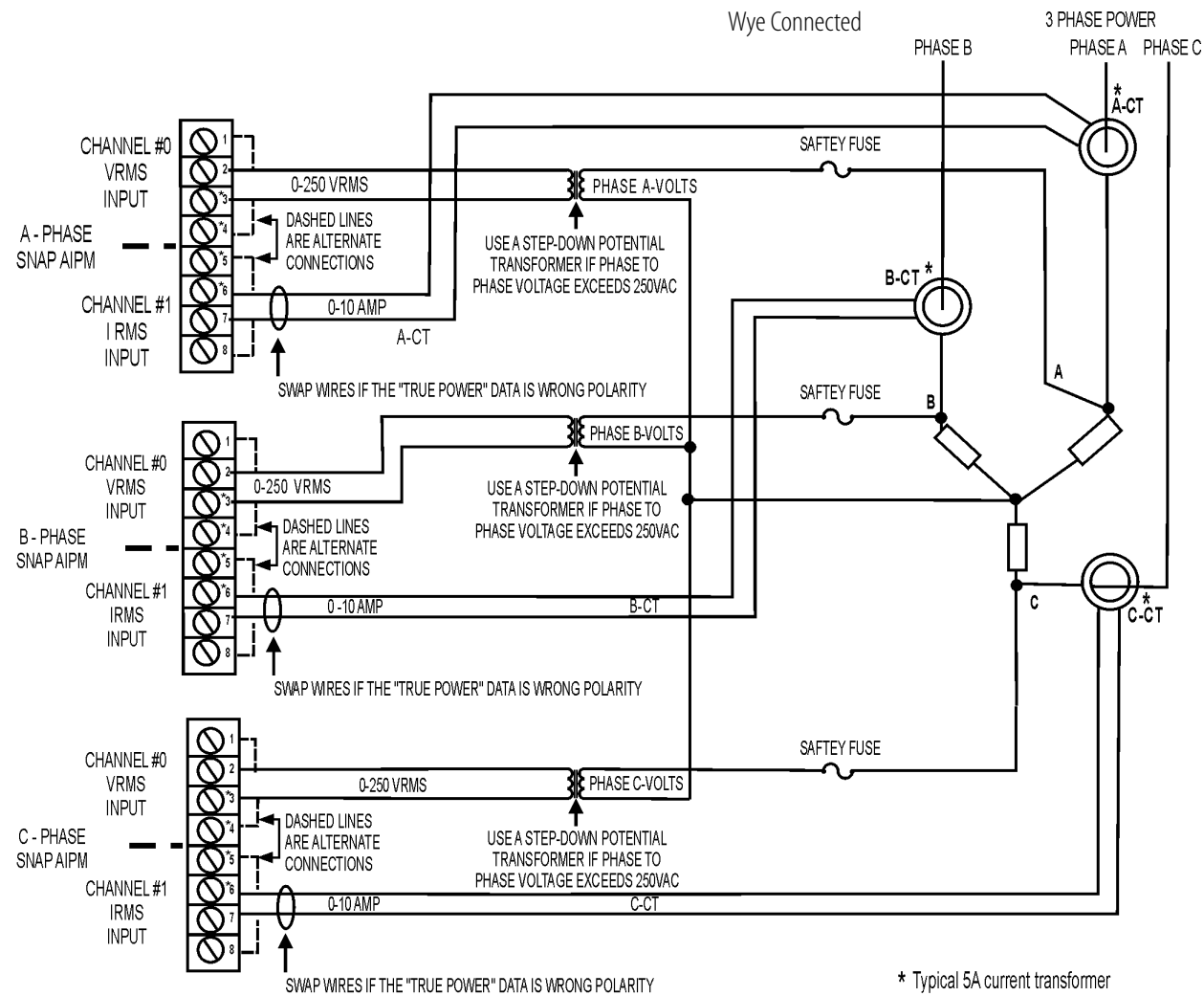

SNAP-AIPM Modules

Wiring Diagrams—SNAP-AIPM (continued)

Three-Phase Wiring to Two SNAP-AIPM Modules

See cautions on [page 4](#). If you have a SNAP-AIPM-3 module, see [page 8](#).

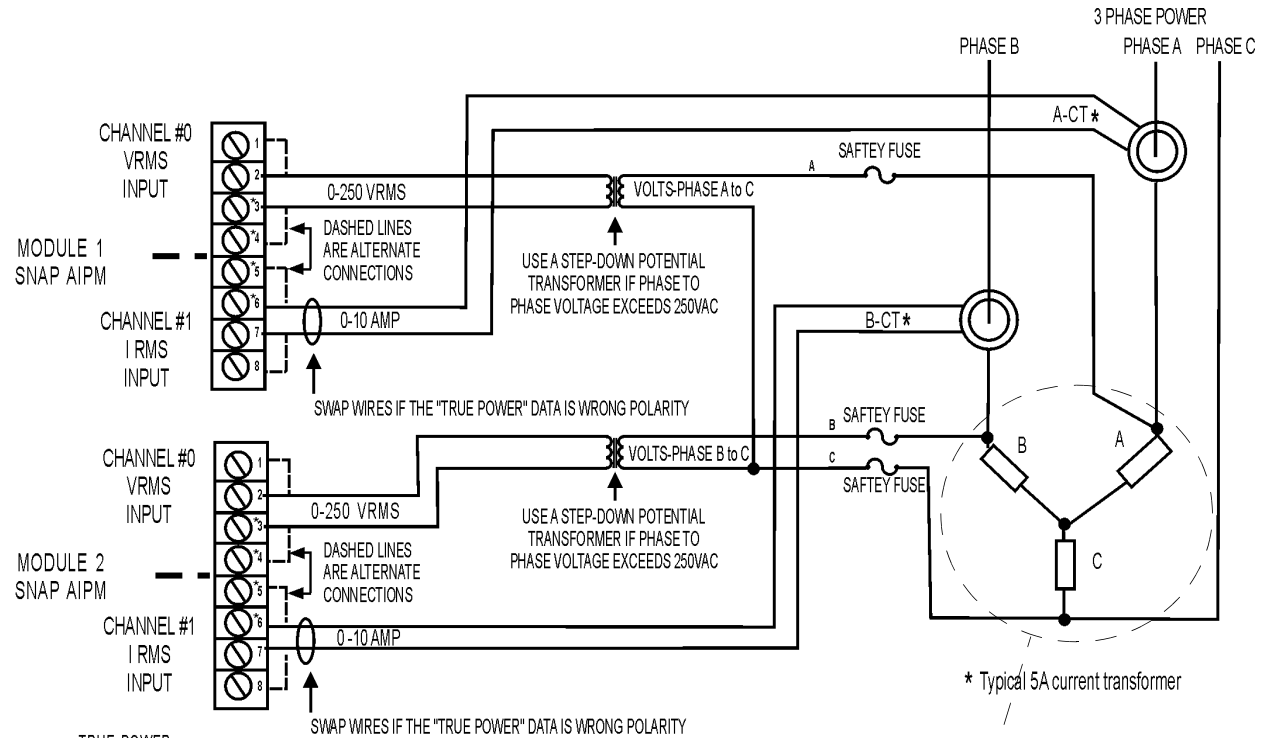

TRUE POWER =
MODULE 1 TRUE POWER + MODULE 2

COMPOSITE VA =
SUM OF BOTH "VA" READINGS X .8660254

NOTE: Three-phase wiring to two modules is used when the neutral of a wye 3-phase is *not* available.

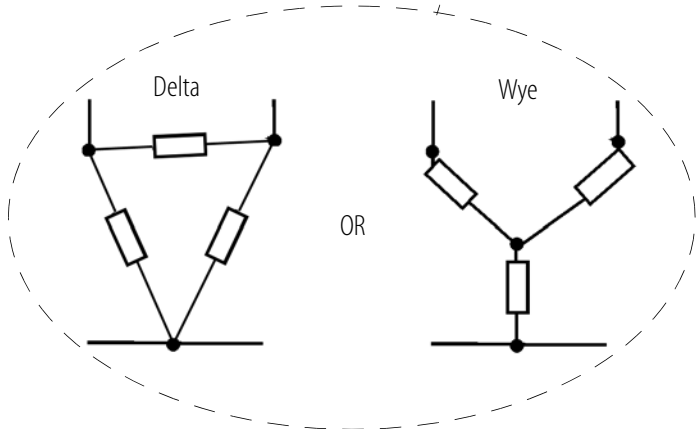

SNAP-AIPM Modules

Wiring Diagrams—SNAP-AIPM-3

Three-Phase Wiring to SNAP-AIPM-3 Module

CAUTION: Be very careful when connecting input channels. **Do not connect line voltage to the current input channel;** such a connection will cause **severe damage** to the module. This damage is **not covered by warranty**. Use a current transformer instead.

CAUTION: Use caution when selecting wire gauges for your application. Use conservative wire gauges with proper voltage ratings.

CAUTION: Terminals 3, 4, 5, and 6 share a common connection inside the module. **Make sure you observe polarity** when connecting the second channel. To avoid a potentially hazardous short circuit, double-check wiring before turning on the current to be monitored.

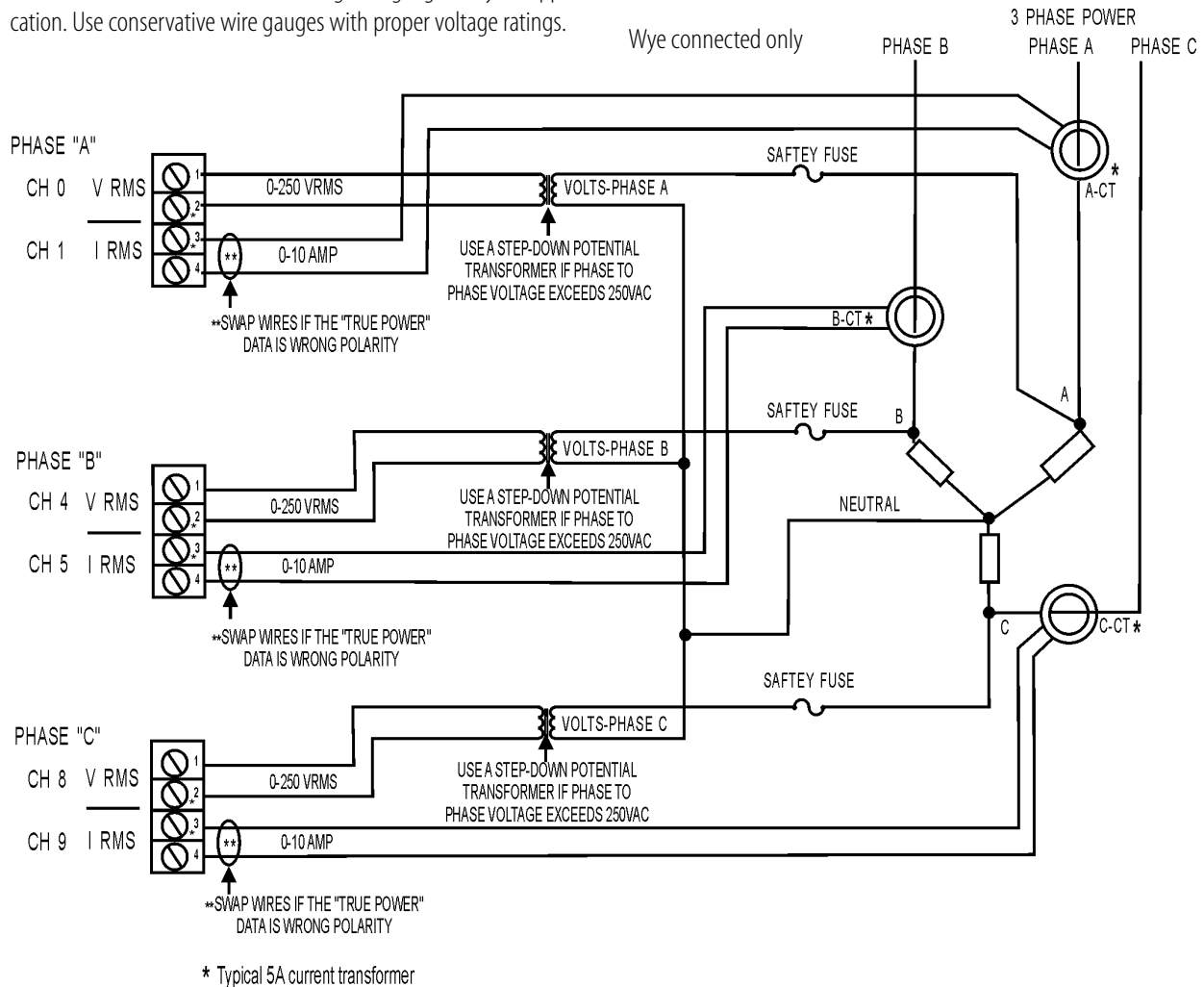

Using this wiring, after you scale the module, the following measurements are available. All measurements are synchronously updated every second:

- | | |
|--|--|
| <ul style="list-style-type: none"> • Individual phase to neutral voltage • Individual phase and load current • Individual phase power • Individual phase volt-amps | <ul style="list-style-type: none"> • 3-phase sum of 1 sec.—signed energy (watt seconds) • 3-phase sum of 1 sec.—unsigned energy (watt sec) |
|--|--|

CAUTION: The SNAP-AIPM-3 module does not contain a fuse. Protect the system by adding a fuse.

Suggested vendors

Protection fuses:
<http://www.littelfuse.com>
 Voltage and current transformers:
<http://www.crmagnetics.com>

SNAP-AIPM Modules

Wiring Diagrams—SNAP-AIPM-3

Three-Phase Wiring to SNAP-AIPM-3 Module

NOTE: This wiring method is less expensive than the one on [page 7](#) but does not provide as much information.

CAUTION: Be very careful when connecting input channels. **Do not connect line voltage to the current input channel;** such a connection will result in **severe damage** to the module. This damage is **not covered by warranty**. Use a current transformer instead.

CAUTION: Use caution when selecting wire gauges for your application. Use conservative wire gauges with proper voltage ratings.

CAUTION: Terminals 3, 4, 5, and 6 share a common connection inside the module. **Make sure you observe polarity** when connecting the second channel. To avoid a potentially hazardous short circuit, double-check wiring before turning on the current to be monitored.

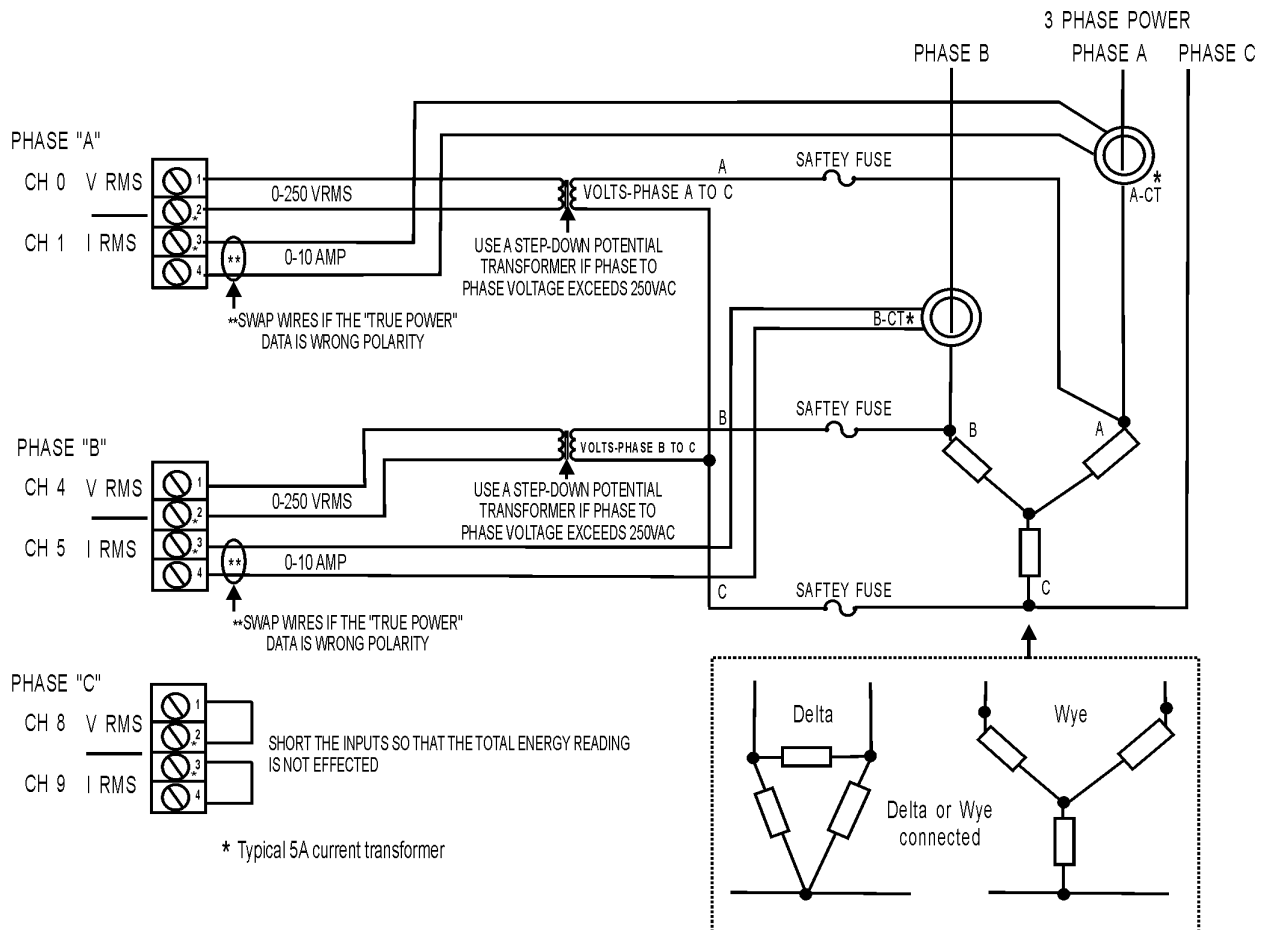

Using this wiring, after you scale the module, the following measurements are available. All measurements are synchronously updated every second:

- Volts, phase A to phase C
- Volts, phase B to phase C
- 3-phase sum of 1 sec.—signed energy (watt seconds)
- 3-phase sum of 1 sec.—unsigned energy (watt secs)

CAUTION: The SNAP-AIPM-3 module does not contain a fuse. Protect the system by adding a fuse.

Suggested vendors

Protection fuses:
<http://www.littelfuse.com>
 Voltage and current transformers:
<http://www.crmagnetics.com>

SNAP-AIPM Modules

Dimensional Drawing—SNAP-AIPM

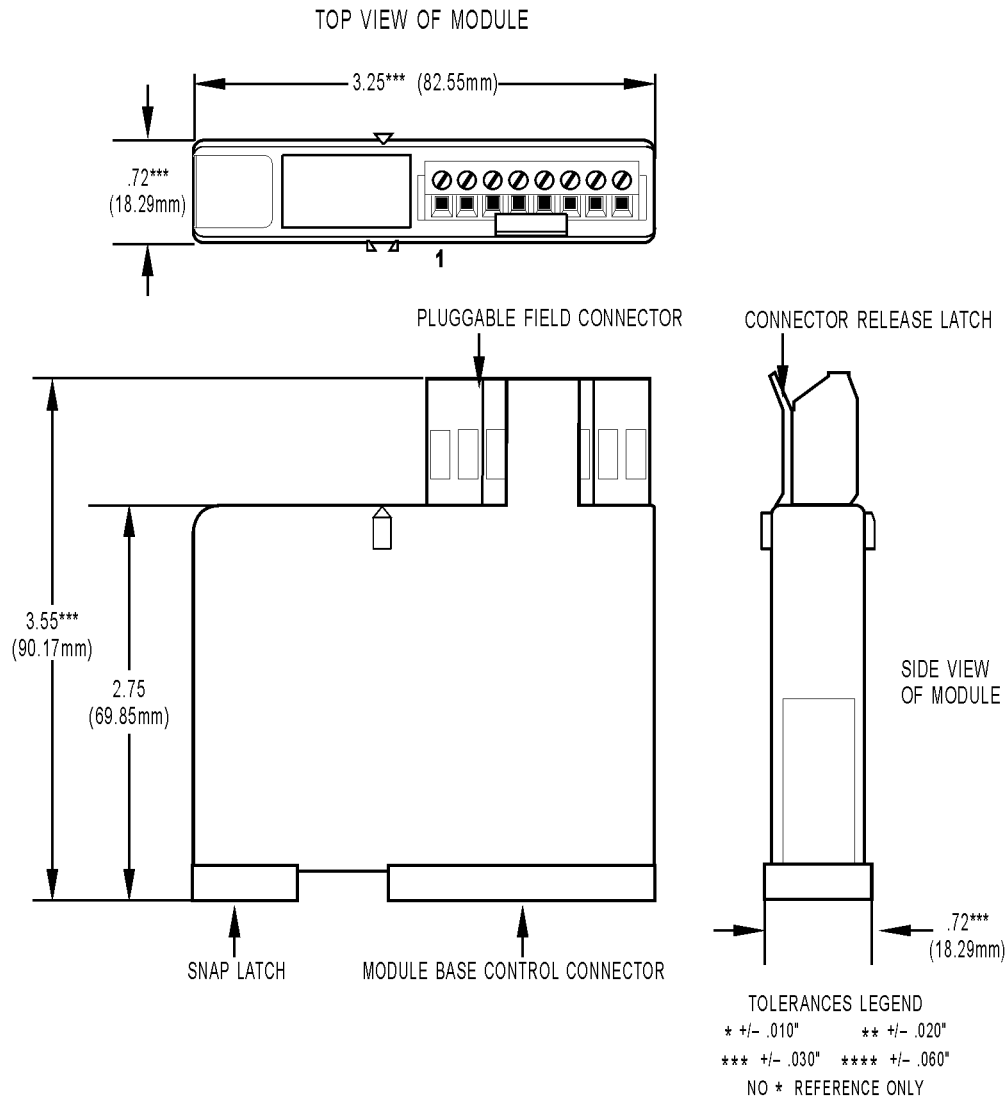

SNAP-AIPM Modules

Dimensional Drawing—SNAP-AIPM-3

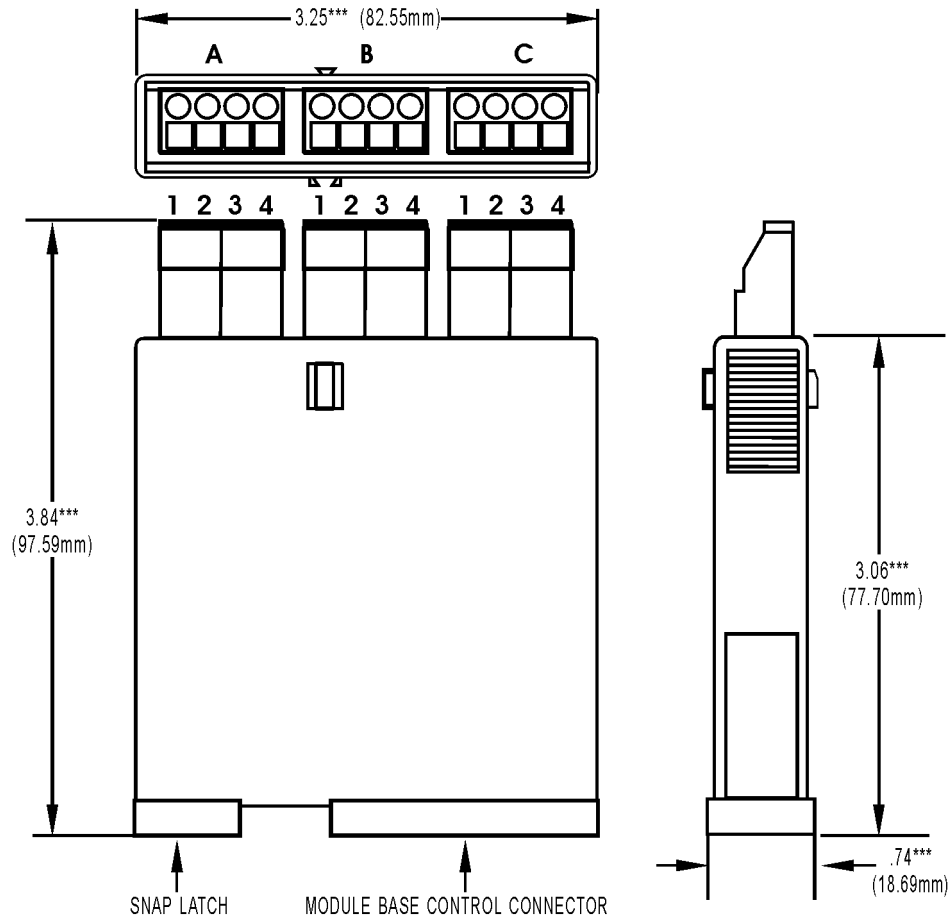

TOLERANCES LEGEND
 * +/- .010" ** +/- .020"
 *** +/- .030" **** +/- .060"
 NO * REFERENCE ONLY

SNAP-AIPM Modules

Dimensional Drawing—All AIPM Modules

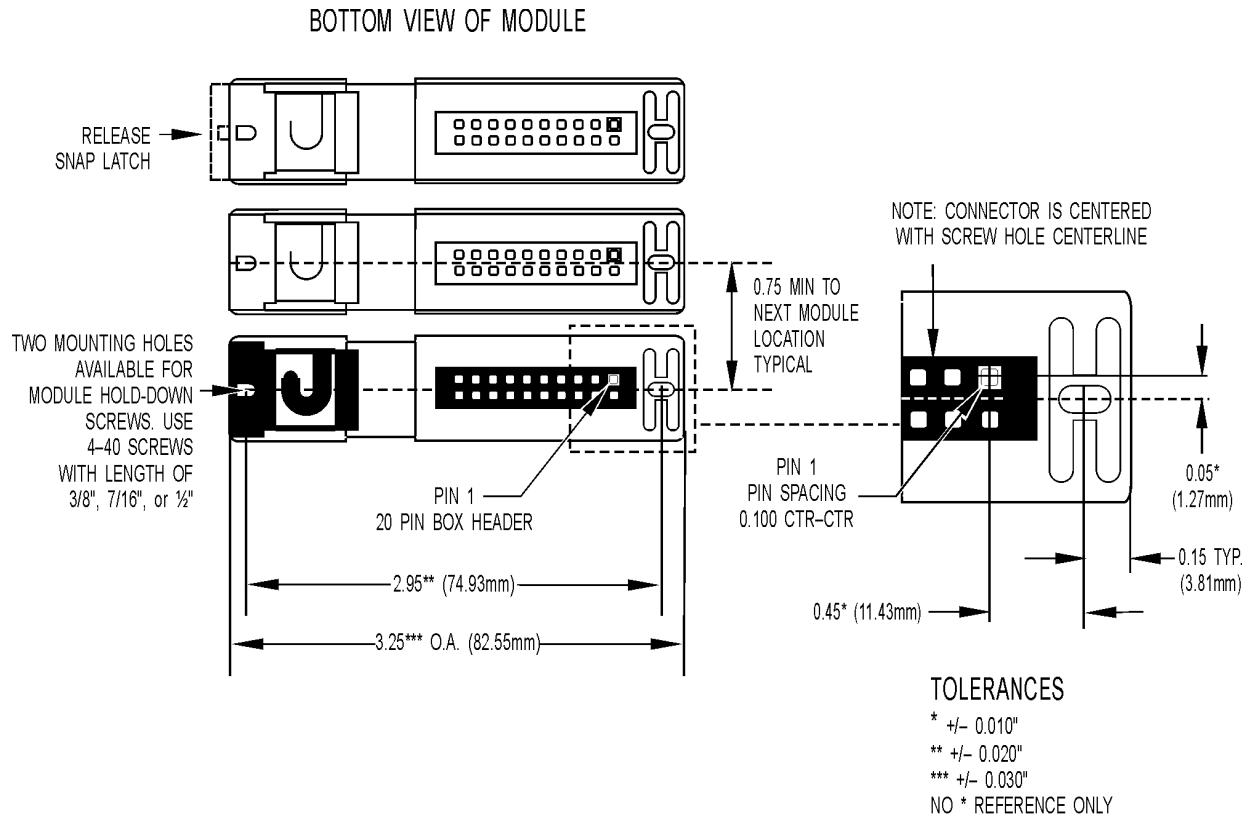

IMPORTANT: The mounting rack connector has 24 pins; the module connector has 20 pins. The extra pins on the mounting rack connector prevent misalignment of the module during installation.

SNAP-AIPM Modules

Dimensional Drawing—All AIPM Modules

NOTE: The SNAP-AIPM-3 has three connectors on the top of the case, at the same height as shown below.

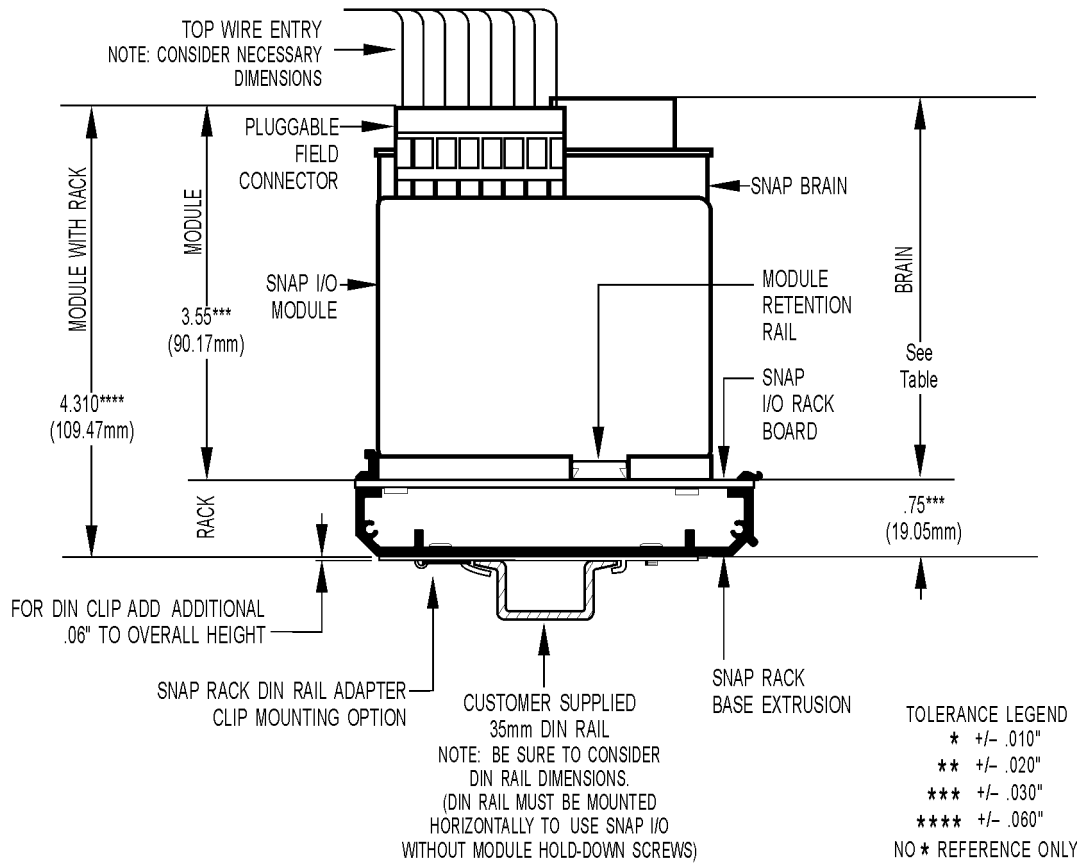

More About Opto 22

Products

Opto 22 develops and manufactures reliable, flexible, easy-to-use hardware and software products for industrial automation, remote monitoring, and data acquisition applications.

SNAP PAC System

Designed to simplify the typically complex process of understanding, selecting, buying, and applying an automation system, the SNAP PAC System consists of four integrated components:

- SNAP PAC controllers
- PAC Project™ Software Suite
- SNAP PAC brains
- SNAP I/O™

SNAP PAC Controllers

Programmable automation controllers (PACs) are multifunctional, multidomain, modular controllers based on open standards and providing an integrated development environment.

Opto 22 has been manufacturing PACs for many years. The latest models include the standalone SNAP PAC S-series and the rack-mounted SNAP PAC R-series. Both handle a wide range of digital, analog, and serial functions and are equally suited to data collection, remote monitoring, process control, and discrete and hybrid manufacturing.

SNAP PACs are based on open Ethernet and Internet Protocol (IP) standards, so you can build or extend a system without the expense and limitations of proprietary networks and protocols.

PAC Project Software Suite

Opto 22's PAC Project Software Suite provides full-featured and cost-effective control programming, HMI (human machine interface) development and runtime, OPC server, and database connectivity software to power your SNAP PAC System.

These fully integrated software applications share a single tagname database, so the data points you configure in PAC Control™ are immediately available for use in PAC Display™, OptoOPCServer™, and OptoDataLink™. Commands are in plain English; variables and I/O point names are fully descriptive.

PAC Project Basic offers control and HMI tools and is free for download on our website, www.opto22.com. PAC Project Professional, available for separate purchase, adds OptoOPCServer, OptoDataLink, options for Ethernet link redundancy or segmented networking, and support for legacy Opto 22 serial *mistic*™ I/O units.

SNAP PAC Brains

While SNAP PAC controllers provide central control and data distribution, SNAP PAC brains provide distributed intelligence for I/O processing and communications. Brains offer analog, digital, and serial functions, including thermocouple linearization; PID loop control; and optional high-speed digital counting (up to 20 kHz), quadrature counting, TPO, and pulse generation and measurement.

SNAP I/O

I/O provides the local connection to sensors and equipment. Opto 22 SNAP I/O offers 1 to 32 points of reliable I/O per module, depending on the type of module and your needs. Analog, digital, serial, and special-purpose modules are all mixed on the same mounting rack and controlled by the same processor (SNAP PAC brain or rack-mounted controller).

Quality

Founded in 1974 and with over 85 million devices sold, Opto 22 has established a worldwide reputation for high-quality products. All are made in the U.S.A. at our manufacturing facility in Temecula, California. Because we do no statistical testing and each part is tested twice before leaving our factory, we can guarantee most solid-state relays and optically isolated I/O modules for life.

Free Product Support

Opto 22's Product Support Group offers free, comprehensive technical support for Opto 22 products. Our staff of support engineers represents decades of training and experience. Product support is available in English and Spanish, by phone or email, Monday through Friday, 7 a.m. to 5 p.m. PST.

Free Customer Training

Hands-on training classes for the SNAP PAC System are offered at our headquarters in Temecula, California. Each student has his or her own learning station; classes are limited to nine students. Registration for the free training class is on a first-come, first-served basis. See our website, www.opto22.com, for more information or email training@opto22.com.

Purchasing Opto 22 Products

Opto 22 products are sold directly and through a worldwide network of distributors, partners, and system integrators. For more information, contact Opto 22 headquarters at 800-321-6786 or 951-695-3000, or visit our website at www.opto22.com.

www.opto22.com